



AMT-MAXI-125/15D					
125 mm - 5"	15 mt - 50 ft	200° C - 392° F	-	-	-
AMT-MAXI-125/ 17D					
125 mm - 5"	17 mt - 56 ft	200° C - 392° F	-	-	-
AMT-MAXI-150/13D					
150 mm - 6"	13 mt - 43 ft	200° C - 392° F	-	-	-
AMT-MAXI-200/10D					
200 mm - 8"	10 mt - 32 ft	200° C - 392° F	-	-	-



 Arrotolatore MAXI dotato di motorizzazione con telecomando per salita e discesa del tubo flessibile di aspirazione. Adatto all'installazione a soffitto e a parete. Completo di finecorsa elettrico di sicurezza e comando remoto di partenza/arresto del ventilatore (centralizzato).

 Motor driven MAXI hose reel with remote control for the roll-up and down of the flexible hose for extraction. Suitable for wall or ceiling installation. Complete with electric safety stop and remote start/stop of the centralized fan.

 Enrouleur MAXI avec montée et descente électrique du tuyau flexible pour l'aspiration des gaz d'échappement avec radio-commande. Installation au mur et au plafond. Equipé d'une fin de course de sécurité qui fonctionne pour le démarrage du ventilateur centralisé.

 Abgasschlauchaufroller MAXI für die Montage an der Wand oder Decke komplett mit Motorantrieb und Fernbedienung funktion Auf- Abrollen des Schläuches und Ein- Ausschalten des Ventilators für eine Zentralanlage. Komplett mit elektrischem Schlauchstopper

 Enrollador MAXI, motorizado para el rebobinado automático de la manguera. Mando a distancia para el control del rebobinado. Puede ser montado en techo o pared. Esta equipado con un 'fin de carrera' eléctrico, que también sirve para el encendido automático del aspirador en instalaciones centralizadas.

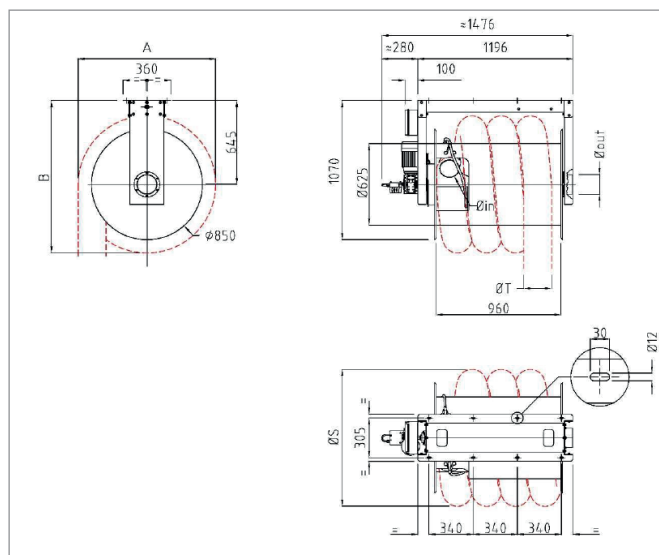

*Peso relativo all'arrotolatore SENZA tubazione flessibile e bocchetta
- Weight of the retractor WITHOUT hose and nozzle - Poids de l'enrouleur SANS tuyau ni buse - Gewicht des Aufrollers OHNE Schlauch und Düse - El peso del retractor SIN manguera ni boquilla.

**Peso relativo all'arrotolatore in versione "COMP" - Weight of the reel in "COMP" version - Poids de la bobine en version "COMP" - Gewicht der Spule in "COMP"-Version - El peso del carrete en la versión "COMP".

Mod	A (mm)	B (mm)	S Ø (mm)	T Ø EXT. (mm)	IN Ø (mm)	OUT Ø (mm)	Kw	Kg*	Kg tot**
AMT-MAXI-125/15	907	1098.5	907	141	125	150	0,25	83	106
AMT-MAXI-125/15-D	907	1098.5	907	141	125	150	0,25	83	106
AMT-MAXI-125/17	907	1098.5	907	141	125	150	0,25	83	108
AMT-MAXI-125/17-D	907	1098.5	907	141	125	150	0,25	83	108
AMT-MAXI-150/13	957	1123.5	907	166	150	150	0,25	83,5	107
AMT-MAXI-150/13-D	957	1123.5	907	166	150	150	0,25	83,5	107
AMT-MAXI 200/10	1053	1171.5	1053	214	200	200	0,25	84	109
AMT-MAXI 200/10-D	1053	1171.5	1053	214	200	200	0,25	84	109